

**OUTER DIMENSIONS OF THE VARIOUS VERSIONS OF
MINILEVEL NT / BLUELEVEL**

**MASSBILDER DER VERSCHIEDENEN AUSFÜHRUNGEN VON
MINILEVEL NT / BLUELEVEL**

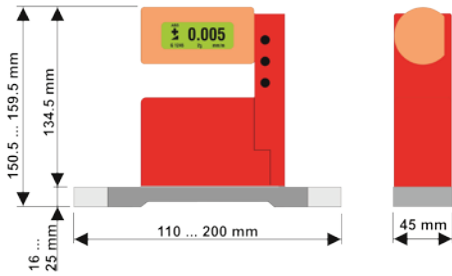

BlueLEVEL
with horizontal base and wireless transmission
mit horizontaler Messbasis und mit Datenübertragung per Funk

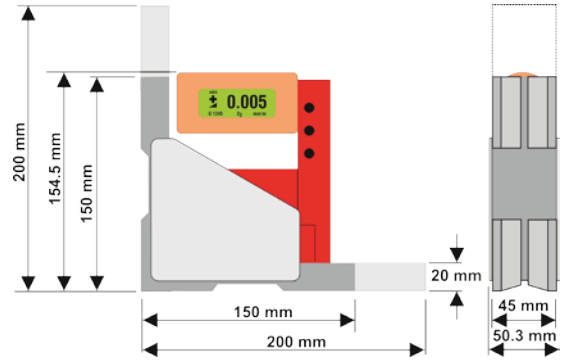

BlueLEVEL
with angular base and wireless transmission
mit Winkelbasis und mit Datenübertragung per Funk

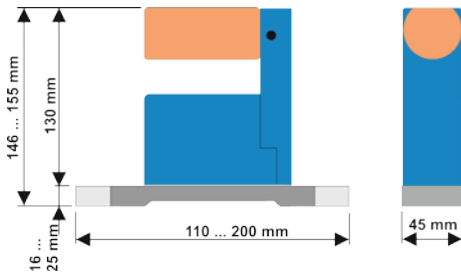

BlueLEVEL BASIC
with horizontal base and wireless transmission
mit horizontaler Messbasis und mit Datenübertragung per Funk

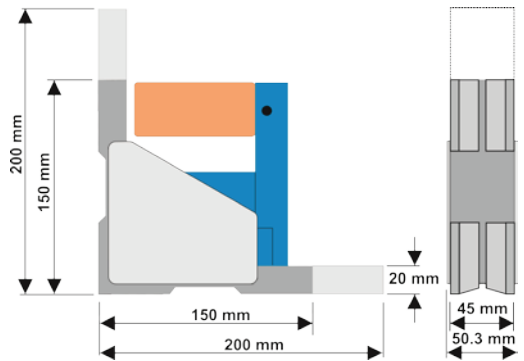

BlueLEVEL BASIC
with angular base and wireless transmission
mit Winkelbasis und mit Datenübertragung per Funk

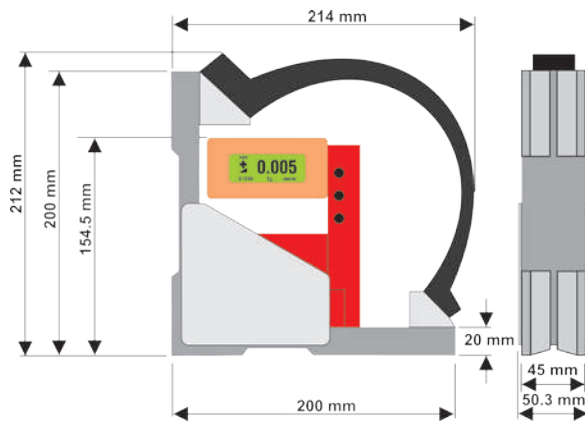

BlueLEVEL / BlueLEVEL BASIC
with nivelSWISS-handle
mit nivelSWISS-Griff
with angular base and wireless transmission
mit Winkelbasis und mit Datenübertragung per Funk

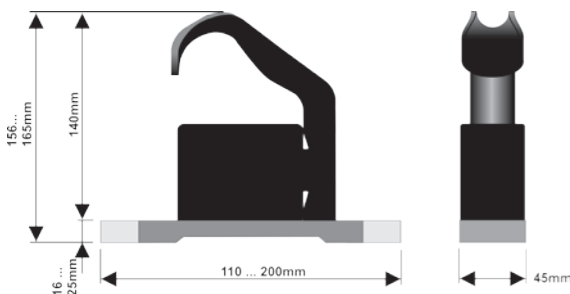

MINILEVEL NT
with horizontal base
mit horizontaler Messbasis

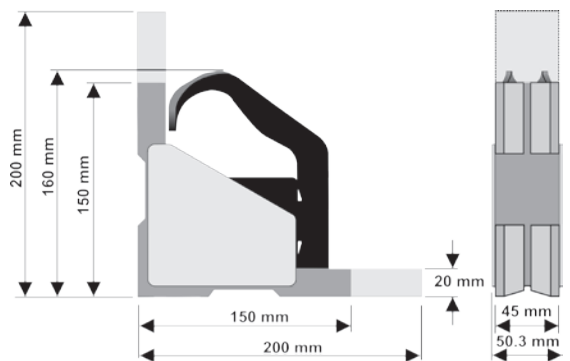

MINILEVEL NT
with angular base
mit Winkelbasis

**SPECIFICATIONS FOR MEASURING BASES FOR
BLUELEVEL / BLUELEVEL BASIC / MINILEVEL NT**

For the BlueLEVEL, BlueLEVEL BASIC and MINILEVEL NT measuring instruments are various horizontal and angular measuring bases available. Depending on the measuring tasks, each of them has its specific advantages.

Short description of the different options:

- Horizontal measuring base, prismatic - for measurements on horizontal surfaces and shafts
- Horizontal measuring base, with dust grooves - particularly suitable for flatness measurements on granite, length 150 and longer with 2 through holes for screwing-on
- Angular base made of cast iron, horizontal and vertical flat - for measurements on horizontal and vertical surfaces as well as for measuring the rectangularity of a measuring object
- Angular base made of cast iron, horizontal and vertical prismatic - for measurements on horizontal and vertical surfaces and shafts as well as for measuring the rectangularity of a measuring object
- Most measuring bases can be ordered with magnetic inserts
- Further options on request

**SPEZIFIKATIONEN FÜR MESSBASEN ZU
BLUELEVEL / BLUELEVEL BASIC / MINILEVEL NT**

Für die Messgeräte BlueLEVEL, BlueLEVEL BASIC und MINILEVEL NT stehen verschiedene horizontale Messbasen und Winkelbasen zur Verfügung. Jede dieser Messbasen hat je nach Anwendung ihre Berechtigung.

Kurzbeschreibung der verschiedenen Varianten:

- Horizontale Messbasis mit Prisma - Einsatz für die Vermessung von horizontalen Flächen und Wellen
- Horizontale Messbasis mit Staubnuten - ausgezeichnet geeignet für die Vermessung von Ebenheiten von Hartsteinobjekten, ab Basislänge 150 mm mit Aufschraubbohrungen
- Winkelbasis aus Grauguss, horizontal+vertikal flach - geeignet für die Vermessung von horizontalen und vertikalen Flächen sowie Rechtwinkligkeitsmessungen an Messobjekten
- Winkelbasis aus Grauguss, horizontal+vertikal prismatisch - geeignet für die Vermessung von horizontalen und vertikalen Flächen und Wellen sowie Rechtwinkligkeitsmessungen an Messobjekten
- Die meisten Messbasen sind mit Magneteinsätzen erhältlich
- Weitere Varianten auf Anfrage

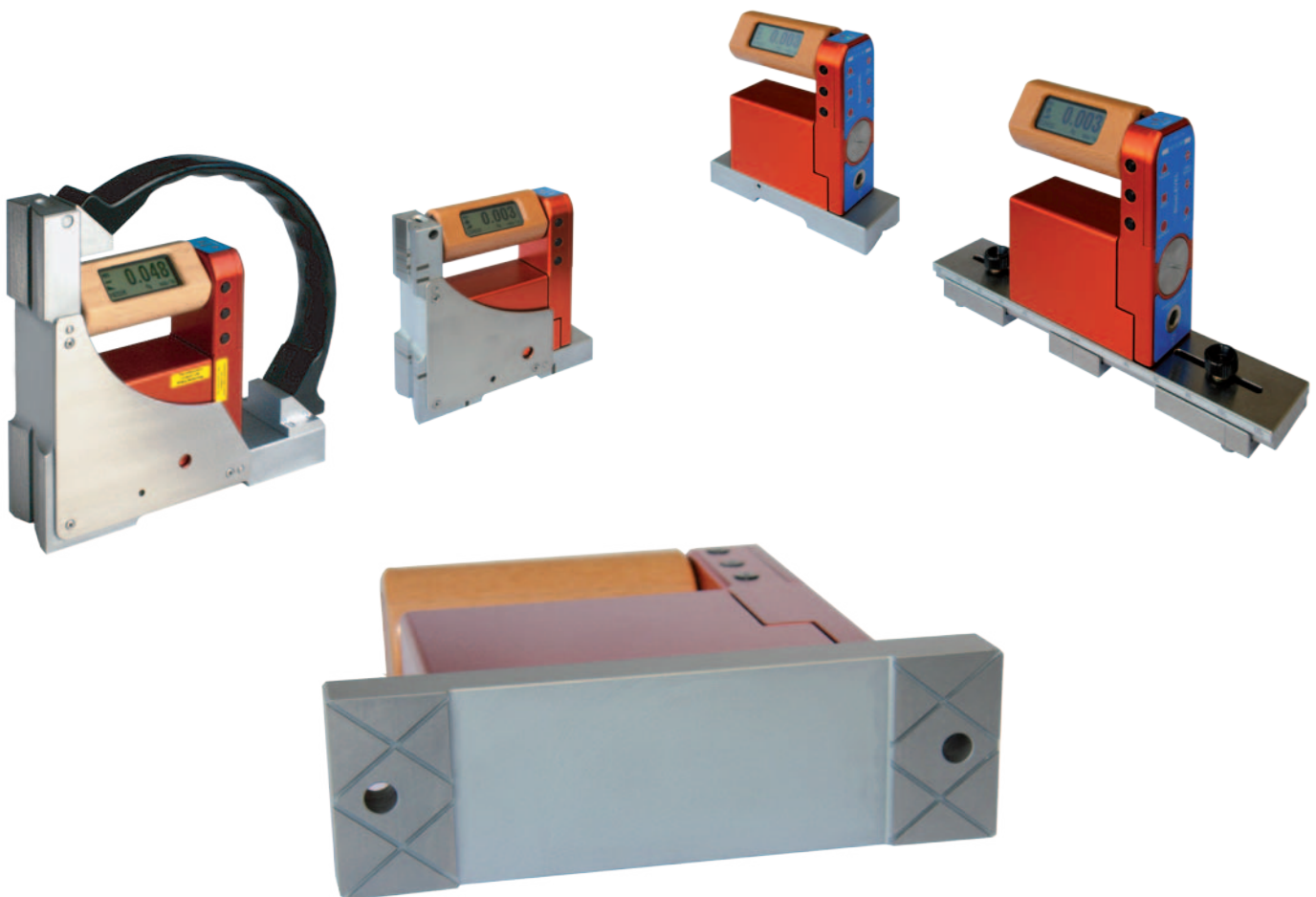

EXAMPLE FOR THE DERIVATION OF A PART NUMBER

BEISPIEL FÜR DIE HERLEITUNG DER ARTIKELNUMMER

STRUCTURE OF A STANDARD PART NUMBER

ttt-bbb-xxx-sss

AUFBAU EINER STANDARD ARTIKELNUMMER

<p>Type of Instrument</p>	<p>016-bbb-xxx-sss</p>  <p>010 – Minilevel A10 011 – MINILEVEL NT 016 – BlueLEVEL</p>	<p>Geräte Typ</p>
----------------------------------	--	--------------------------

<p>Length of base [mm]</p>	<p>ttt-150-xxx-sss</p> <p>110 – 110 mm 150 – 150 mm 200 – 200 mm</p>	<p>Länge der Messbasis [mm]</p>
-----------------------------------	--	--

<p>Base type</p> <p>Shape Horizontal base Angular base Frame base</p> <p>Measuring contact faces Flat Prismatic Magnetic inserts</p> <p>Material Cast iron Hardened steel Aluminum</p>	<p>ttt-bbb-243-sss</p> 	<p>Basentyp</p> <p>Form Horizontalbasis Winkelbasis Rahmen</p> <p>Messflächen Flach Prismatisch Magneteinsätze</p> <p>Material Grauguss Stahl gehärtet Aluminium</p>
--	--	--

<p>Sensitivity</p>	<p>ttt-bbb-xxx-001</p> <p>001 – 0.001 mm/m 005 – 0.005 mm/m</p>	<p>Zifferschnittwert (Empfindlichkeit)</p>
---------------------------	---	---

<p>BlueLEVEL</p> <p>Angular base, cast iron Base length 150 mm Prismatic contact faces Sensitivity 0.001 mm/m</p>	<p>016-150-243-001</p> 	<p>BlueLEVEL</p> <p>Winkelbasis, Grauguss Basenlänge 150 mm Prismatische Messflächen Zifferschnittwert 0.001 mm/m</p>
--	--	--

DRILLING PATTERN FOR ALL MEASURING BASES

BOHRBILD FÜR ALLE MESSBASEN

MINILEVEL NT + BlueLEVEL + ZEROTRONIC-Sensor

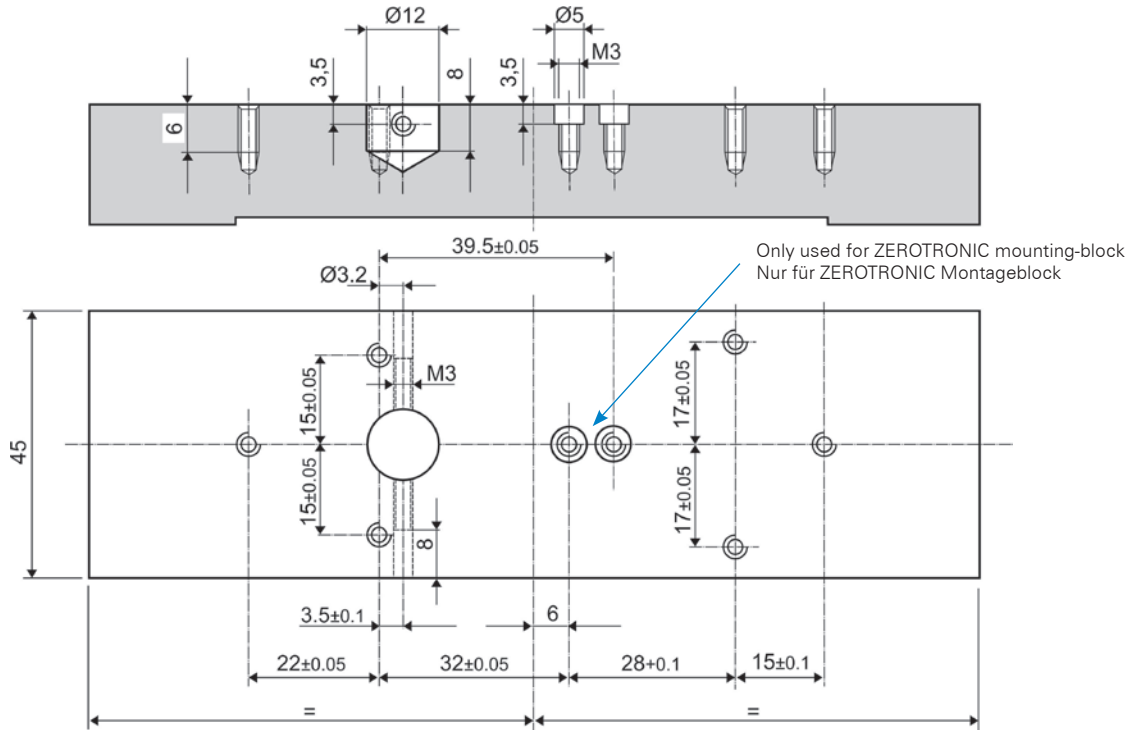

HORIZONTAL MEASURING BASES WITH FLAT CONTACT FACES

HORIZONTALE MESSBASEN MIT FLACHEN AUFLAGEFLÄCHEN

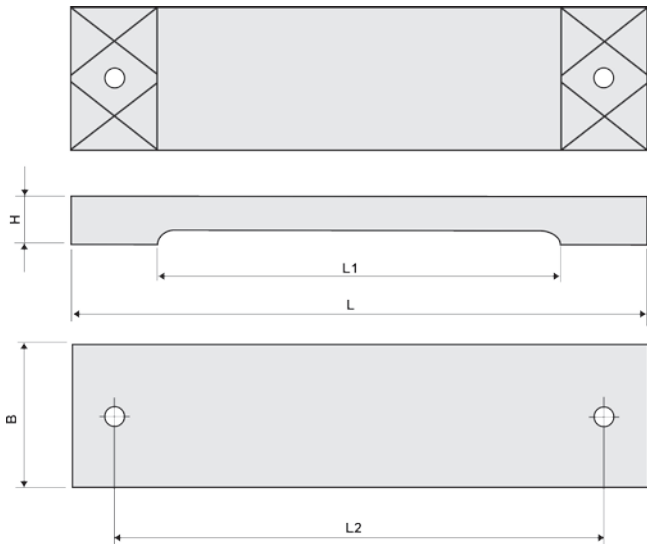

L [mm]	L1 [mm]	L2 [mm]	B [mm]	H [mm]	Weight / Gewicht	
					Aluminum Aluminium [kg]	Cast iron Grauguss [kg]
110	68	---	45	16	0.192	0.575
150	100	130	45	16	0.258	0.776
200	140	170	45	20	0.450	1.350

General:

- Horizontal measuring base
- Flat contact faces precision lapped
- 2 through holes Ø 7 mm (for base length 150 mm and 200 mm)

Allgemein:

- Horizontale Messbasis
- Flache Auflageflächen präzise geläpft
- 2 Durchgangsbohrungen Ø 7 mm (für Basislängen 150 mm und 200 mm)

- Hardened steel
- Contact faces with dust grooves
- Other surfaces nickel-plated

ttd-<bbb>-122-<sss>

- Stahl gehärtet
- Flache Auflageflächen mit Staubnuten
- Übrige Flächen vernickelt

- Aluminum
- Surfaces hard-anodised with PTFE

ttd-<bbb>-126-<sss>

- Aluminium
- Oberflächen alteferti

HORIZONTAL MEASURING BASES WITH FLAT CONTACT FACES

HORIZONTALE MESSBASEN MIT FLACHEN AUFLAGEFLÄCHEN

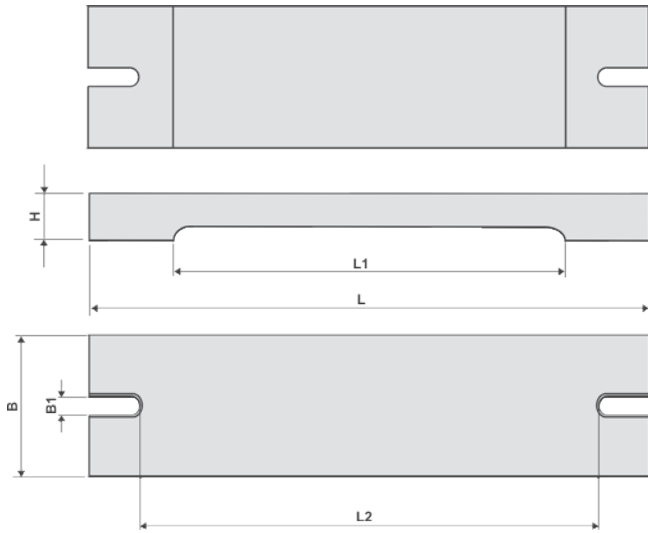

L	L1	L2	B	B1	H	Weight / Gewicht	
						Aluminum Aluminium	Cast iron Grauguss
[mm]	[mm]	[mm]	[mm]	[mm]	[mm]	[kg]	[kg]
150	100	113	45	7	16	0.253	0.760
200	140	162	45	7	20	0.417	1.250

General:

- Horizontal measuring base
- Flat contact faces with slots at either end

Allgemein:

- Horizontale Messbasis
- Flache Auflageflächen mit Schlitten an beiden Enden

- Cast iron
- Contact faces hand scraped
- Other surfaces nickel-plated

ttt-<bbb>-133-<sss>

- Grauguss
- Auflageflächen handgeschabt
- Übrige Flächen vernickelt

- Aluminum
- Surfaces hard-anodised with PTFE

ttt-<bbb>-136-<sss>

- Aluminium
- Oberflächen alufertig

HORIZONTAL SCREW-ON MEASURING BASES FOR ADAPTION OF HORIZONTAL MEASURING BASES WITH

- 2 THROUGH HOLES Ø 7 MM DISTANCE 130 MM
- SLOTS AT EITHER END

HORIZONTALE AUFSCHRAUB-MESSBASEN ZUR ADAPTION VON HORIZONTAL EN MESSBASEN MIT

- 2 DURCHGANGSBOHRUNGEN Ø 7 MM ABSTAND 130 MM
- SCHLITZEN AN BEIDEN ENDEN

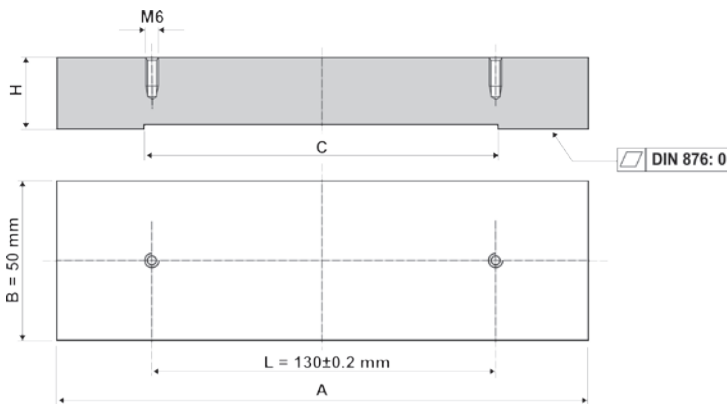

A	B	C	H	Weight / Gewicht
[mm]	[mm]	[mm]	[mm]	[kg]
200	50	80	35	1.050
250	50	100	40	1.500
500	50	200	80	5.950

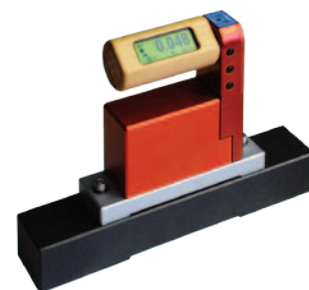

General:

- Horizontal screw on measuring base
- Flat contact faces
- Granite

Allgemein:

- Horizontale Aufschraub-Messbasis
- Flache Auflageflächen
- Hartgestein

Base length 200 mm

051-200-124-130

Basislänge 200 mm

Base length 250 mm

051-250-124-130

Basislänge 250 mm

Base length 500 mm

051-500-124-130

Basislänge 500 mm

HORIZONTAL MEASURING BASES WITH FLAT CONTACT FACES

HORIZONTALE MESSBASEN MIT FLACHEN AUFLAGEFLÄCHEN

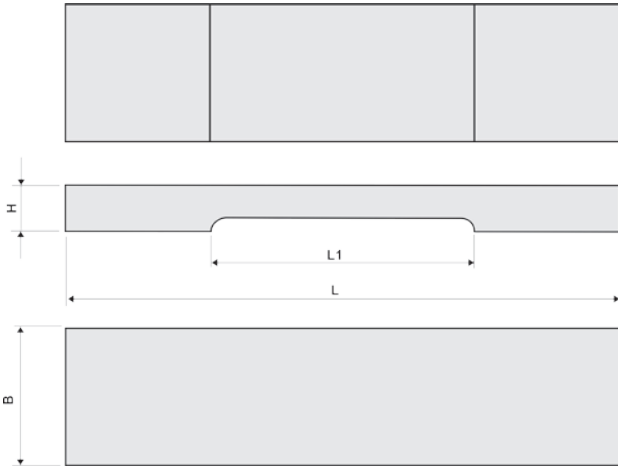

L [mm]	L1 [mm]	B [mm]	H [mm]	Weight / Gewicht [kg]
110	40	45	16	0.600
150	50	45	20	0.760
200	80	45	24	1.250

General:

- Horizontal measuring base
- Flat contact faces

Allgemein:

- Horizontale Messbasis
- Flache Auflageflächen

<ul style="list-style-type: none"> • Cast iron • Contact faces hand scraped • Other surfaces nickel-plated 	ttt-<bbb>- 123 -<sss>	<ul style="list-style-type: none"> • Grauguss • Auflageflächen handgeschabt • Übrige Flächen vernickelt
<ul style="list-style-type: none"> • Aluminum • Contact faces precision lapped • Surfaces hard-anodised with PTFE 	ttt-<bbb>- 126 -<sss>	<ul style="list-style-type: none"> • Aluminium • Auflageflächen präzise geläppt • Oberflächen altefieri
<ul style="list-style-type: none"> • Cast iron • Contact faces hand scraped • Other surfaces nickel-plated • Magnetic inserts 	ttt-<bbb>- 127 -<sss>	<ul style="list-style-type: none"> • Grauguss • Auflageflächen handgeschabt • Übrige Flächen vernickelt • Magneteinsätze

HORIZONTAL MEASURING BASES WITH PRISMATIC CONTACT FACES

HORIZONTALE MESSBASEN MIT PRISMATISCHEN AUFLAGEFLÄCHEN

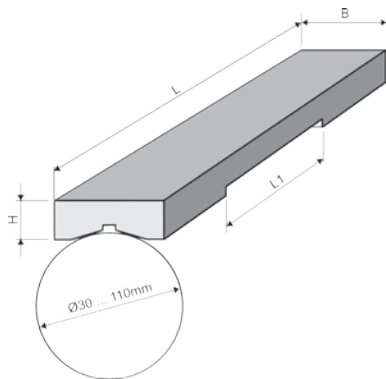

L [mm]	B [mm]	L1 [mm]	H [mm]	Weight / Gewicht	
				Aluminum Aluminium [kg]	Cast iron Grauguss [kg]
110	45	40	15	0.150	0.436
150	45	50	19	0.260	0.790
200	45	80	24	0.430	1.300

General:

- Horizontal measuring base
- Prismatic contact faces

Allgemein:

- Horizontale Messbasis
- Prismatische Auflageflächen

<ul style="list-style-type: none"> • Cast iron • Contact faces hand scraped • Other surfaces nickel-plated 	ttt-<bbb>- 113 -<sss>	<ul style="list-style-type: none"> • Grauguss • Auflageflächen handgeschabt • Übrige Flächen vernickelt
<ul style="list-style-type: none"> • Aluminum • Contact faces precision lapped • Surfaces hard-anodised with PTFE • Does not comply with DIN 877 	ttt-<bbb>- 116 -<sss>	<ul style="list-style-type: none"> • Aluminium • Auflageflächen präzise geläppt • Oberflächen altefieri • Erfüllt nicht DIN 877
<ul style="list-style-type: none"> • Cast iron • Contact faces hand scraped • Other surfaces nickel-plated • Magnetic inserts 	ttt-<bbb>- 117 -<sss>	<ul style="list-style-type: none"> • Grauguss • Auflageflächen handgeschabt • Übrige Flächen vernickelt • Magneteinsätze

HORIZONTAL MEASURING BASES WITH PRISMATIC CONTACT FACES FOR LARGE SHAFTS

HORIZONTALE MESSBASEN MIT PRISMATISCHEN AUFLAGEFLÄCHEN FÜR GROSSE WELLEN

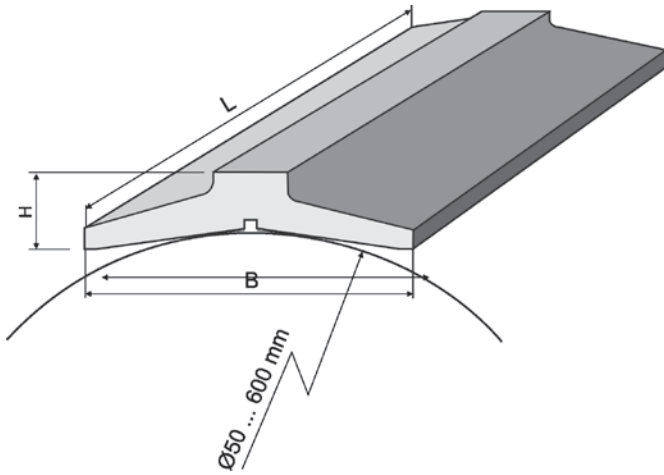

L [mm]	B [mm]	H [mm]	Weight / Gewicht [kg]
110	150	49	2.400
150	150	49	3.300
200	150	49	4.650

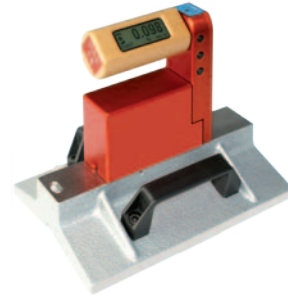

- General:**
- Horizontal measuring base
 - Prismatic contact faces for shafts with Ø 50 ... 600 mm
 - Cast iron
 - Contact faces hand scraped
 - Other surfaces spray painted

- Allgemein:**
- Horizontale Messbasis
 - Prismatische Auflageflächen für Wellen mit Ø 50 ... 600 mm
 - Grauguss
 - Auflageflächen handgeschabt
 - Übrige Flächen Hammerschlag lackiert

Length 110mm	ttt-110-173-<sss>	Länge 110mm
Length 150mm	ttt-150-173-<sss>	Länge 150mm
Length 200mm	ttt-200-173-<sss>	Länge 200mm

HORIZONTAL MEASURING FLEX-BASE WITH THREE-POINT CONTACT FACES

HORIZONTALE FLEX-MESSBASIS MIT DREIPUNKT-AUFLAGEFLÄCHEN

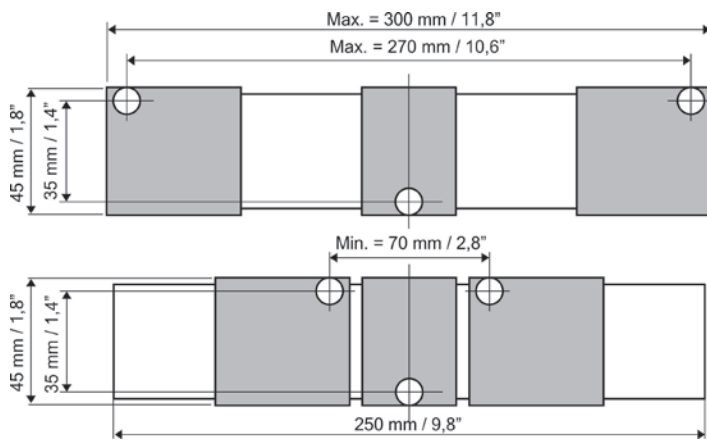

Length L Länge L [mm]	Width B Breite B [mm]	Height H Höhe H [mm]	Weight / Gewicht [kg]
250 ... 300	45	22	1.3 kg

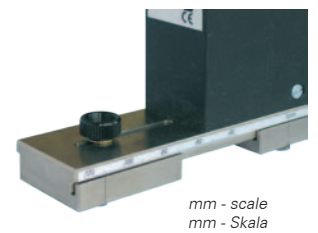
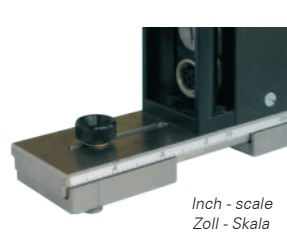

- General:**
- Horizontal measuring FLEX-base with three point tungsten carbide contact faces Ø 10 mm
 - Scale in [mm] and [inch]

- Allgemein:**
- Horizontale FLEX-Messbasis mit 3-Punkt-Hartmetall-auflagen Ø 10 mm
 - Skalenteilung in [mm] und [Zoll]

ttt-250-453-<sss>		
Adjustable step length	144 ... 240 mm 5,7 ... 9,4"	Verstellbare Schrittlänge
After conversion min.	70 mm 2,8"	Nach Umbau min.
After conversion max.	270 mm 10,6"	Nach Umbau max.

ANGULAR MEASURING BASES

WINKELMESSBASEN

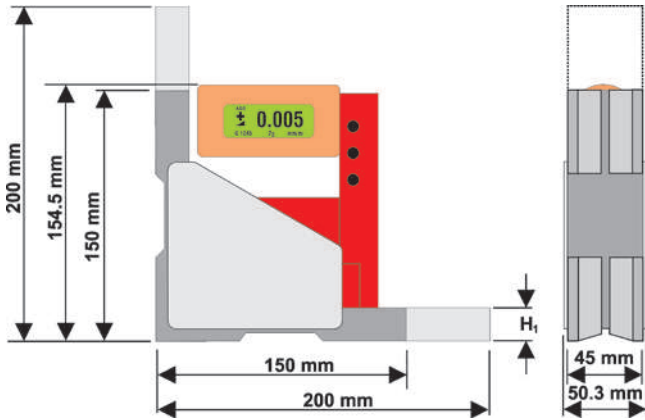

Length L Länge L [mm]	Width B Breite B [mm]	Height H Höhe H [mm]	Height H ₁ Höhe H ₁ [mm]	Weight / Gewicht [kg]
150	45 ... 50.3	150 ... 154.5	20	1.700
200	45 ... 50.3	200	24	2.750

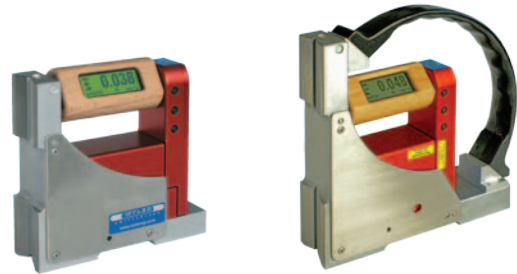

General:

- Angular measuring bases
- Cast iron
- Contact faces hand scraped
- Other surfaces nickel-plated

Allgemein:

- Winkelmessbasen
- Grauguss
- Auflageflächen handgeschabt
- Übrige Flächen vernickelt

Horizontal base			Vertical base			Horizontale Basis			Vertikale Basis		
flat	prismatic	Magnetic inserts	flat	prismatic	Magnetic inserts	flach	prismatisch	Magnet-einsätze	flach	prismatisch	Magnet-einsätze
X			X			X			X		
X			X		X	X			X		X
X		X	X		X	X		X	X		X
X		X	X			X		X	X		
X				X		X				X	
X				X	X	X				X	X
X		X		X	X	X		X		X	X
X		X		X		X		X	X		
	X		X				X		X		
	X		X		X		X		X		X
	X	X	X		X		X	X	X		X
	X	X	X				X	X	X		
	X			X			X			X	
	X			X	X		X			X	X
	X	X		X	X		X	X		X	X
	X	X		X			X	X		X	

General:

- Angular measuring bases
- Cast iron
- Contact faces hand scraped
- Other surfaces nickel-plated
- Special handle from nivelSWISS

Allgemein:

- Winkelmessbasen
- Grauguss
- Auflageflächen handgeschabt
- Übrige Flächen vernickelt
- Mit Spezialgriff vom nivelSWISS

Horizontal base			Vertical base			Horizontale Basis			Vertikale Basis		
flat	prismatic	Magnetic inserts	flat	prismatic	Magnetic inserts	flach	prismatisch	Magnet-einsätze	flach	prismatisch	Magnet-einsätze
X			X			X			X		
	X			X			X			X	
X			X		X ¹⁾	X			X		X ¹⁾

¹⁾Remark: Small magnetic inserts, do not hold the instrument

¹⁾Bemerkung: Kleine Magneteinsätze, nicht selbsthaftend